

B

SEE

TTT
天科技

à B CE•

“

n

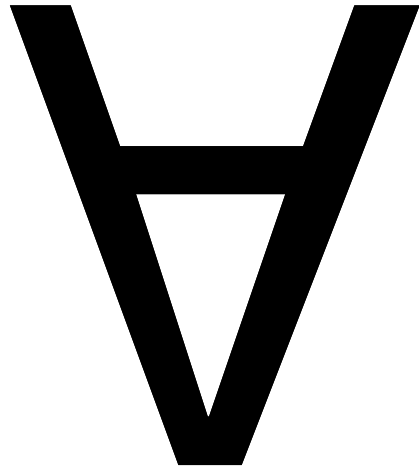

ÑA ‡ ' : ÓÃ

| | |
|--|--|
| | |
| | |
| | |
| | |



0
D

Q i ' e 8 Q e Q
D

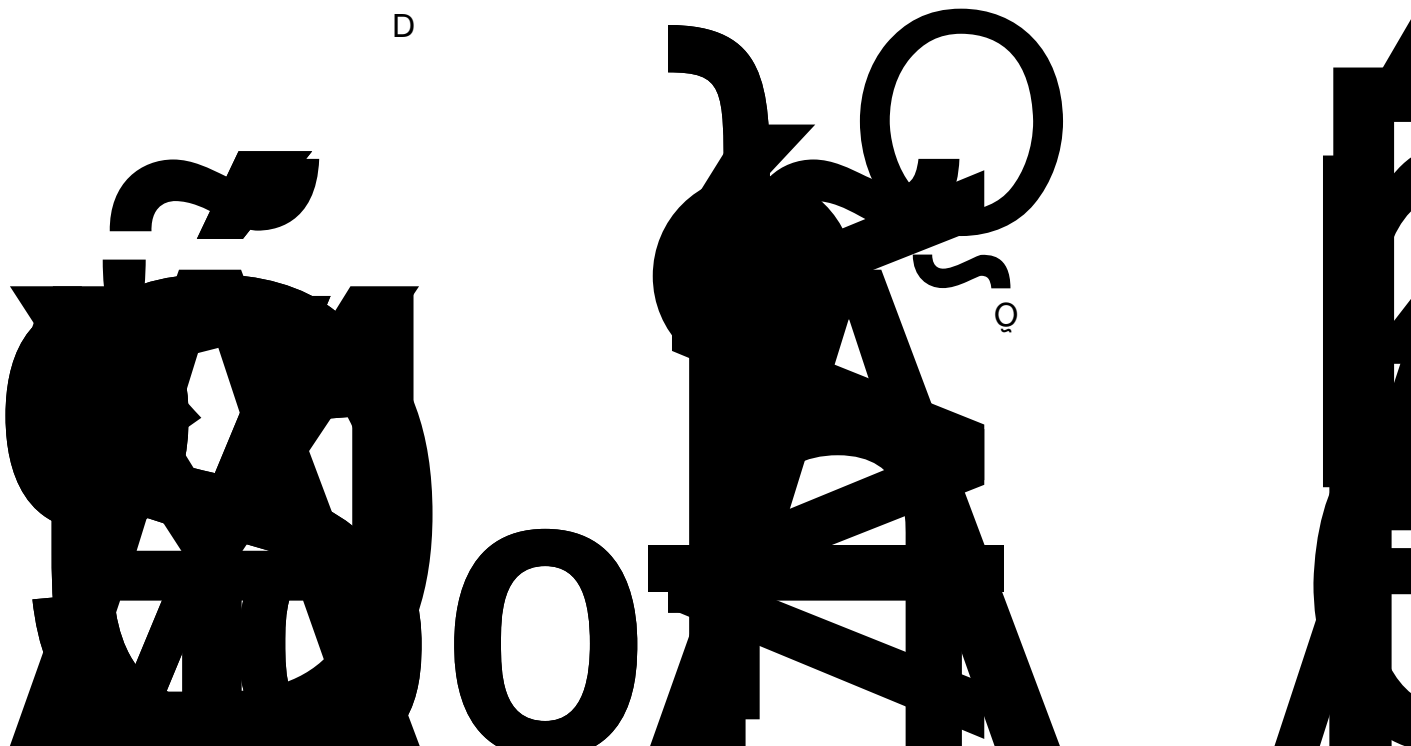

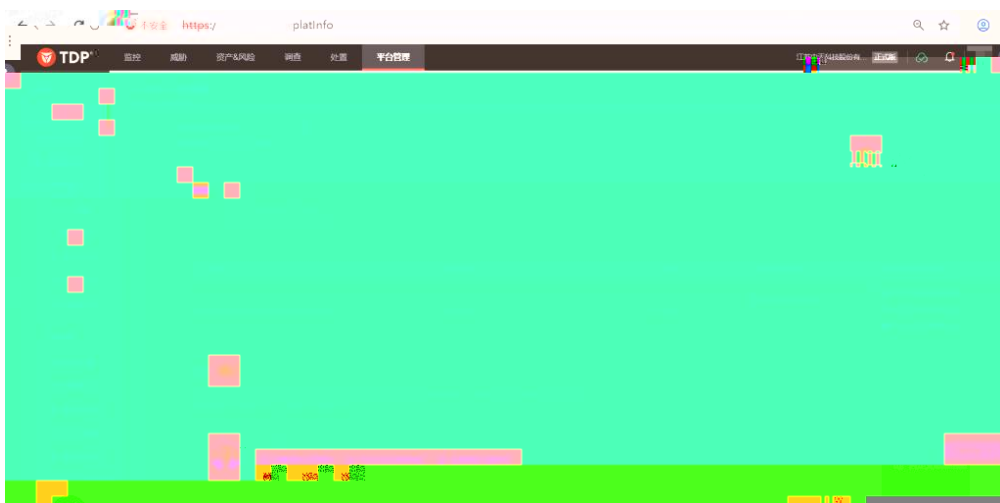

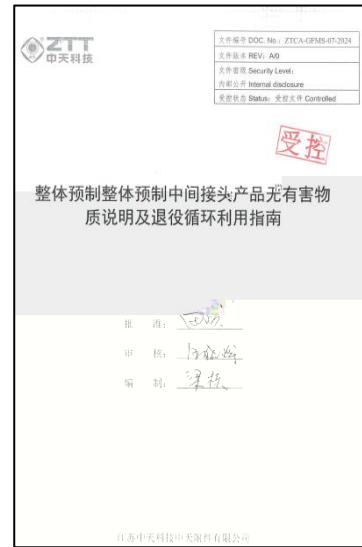
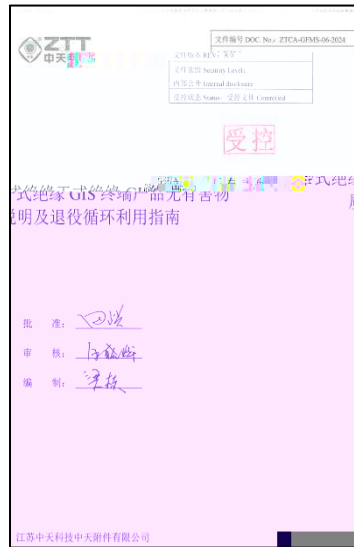
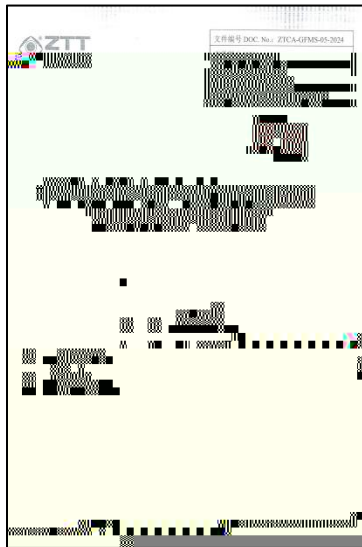

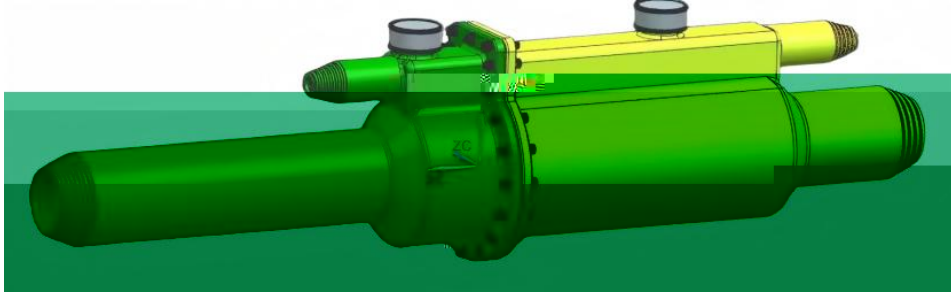

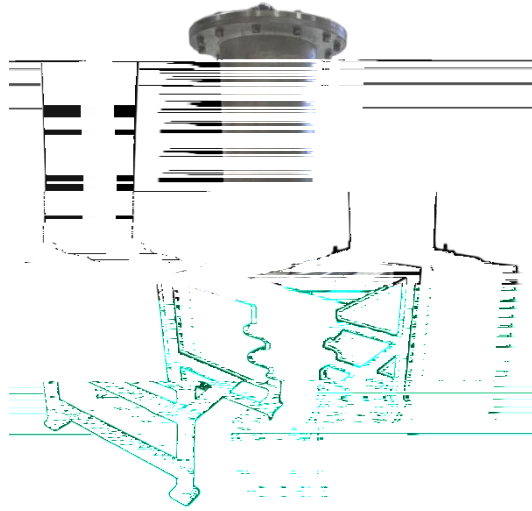

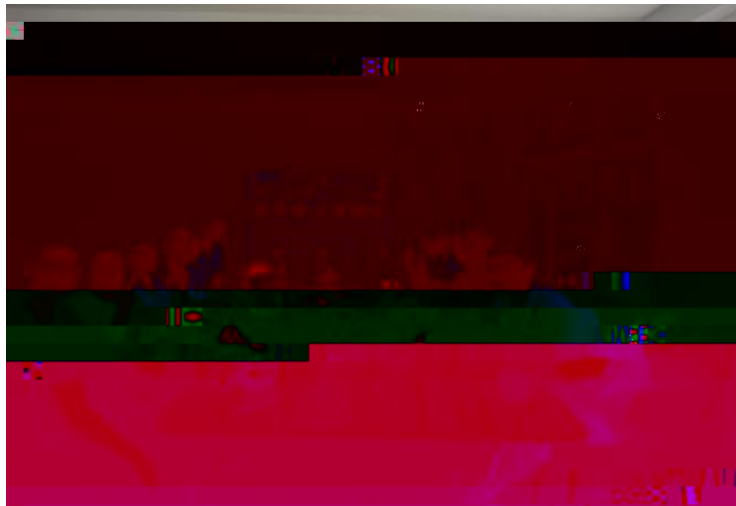
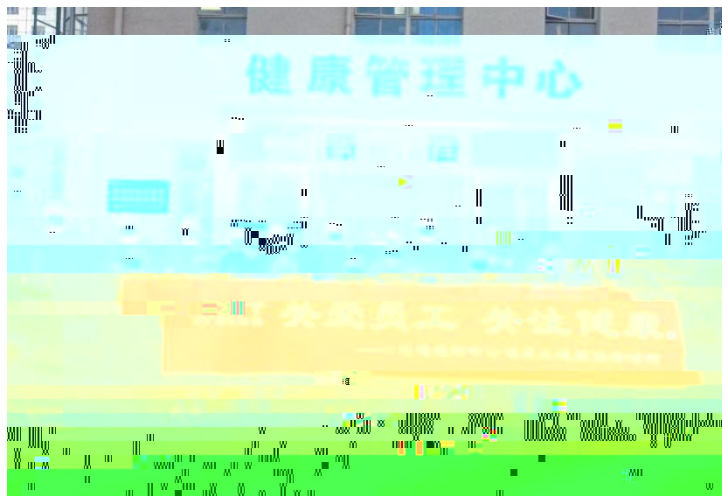



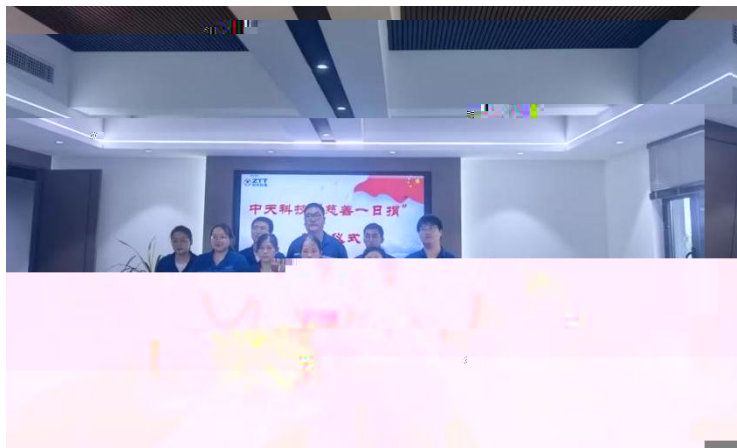
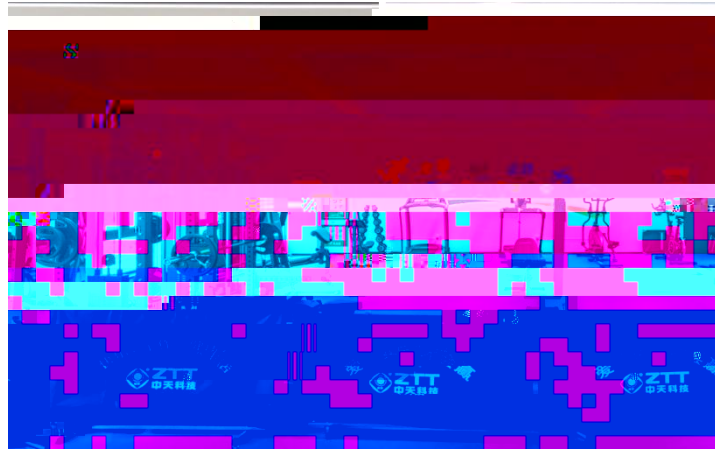



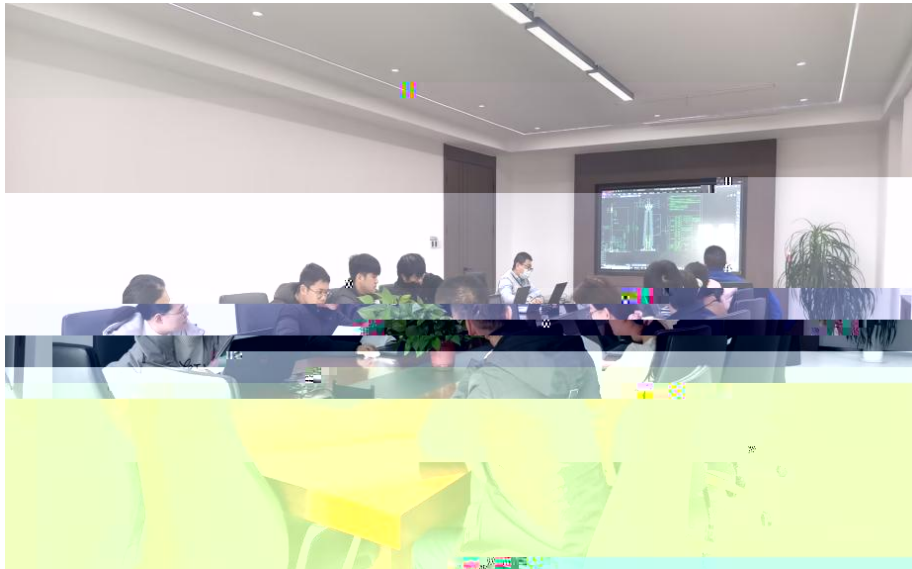

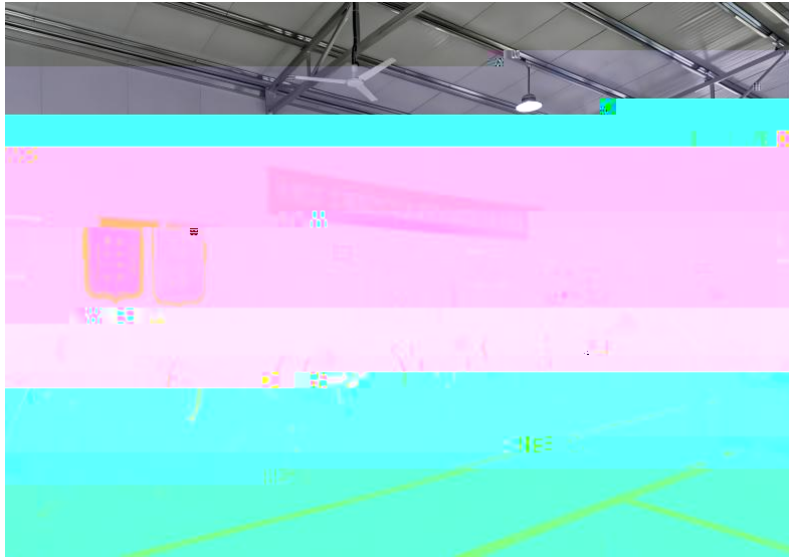

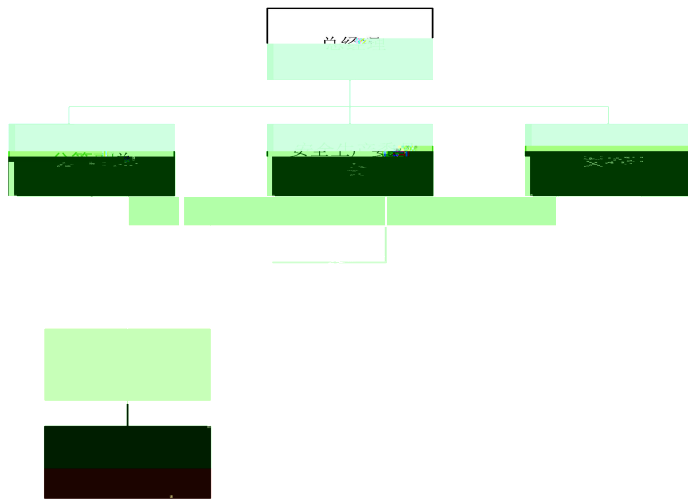

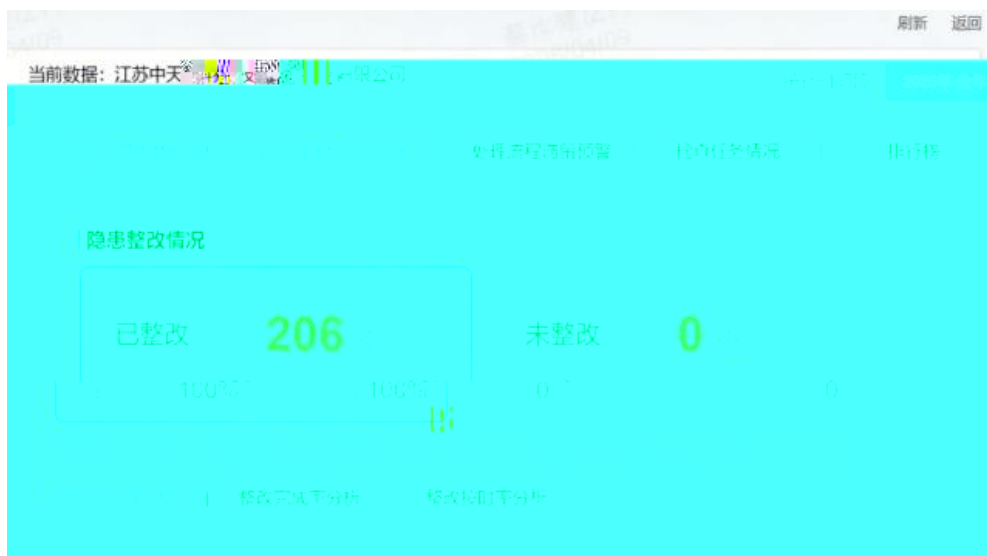

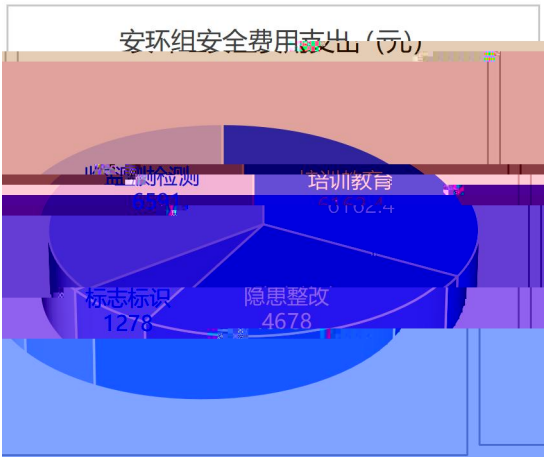
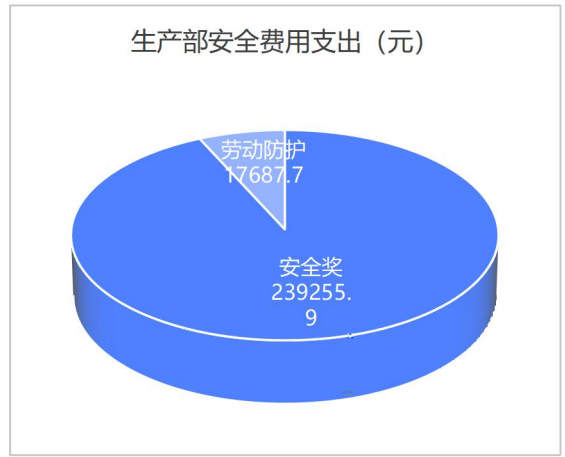
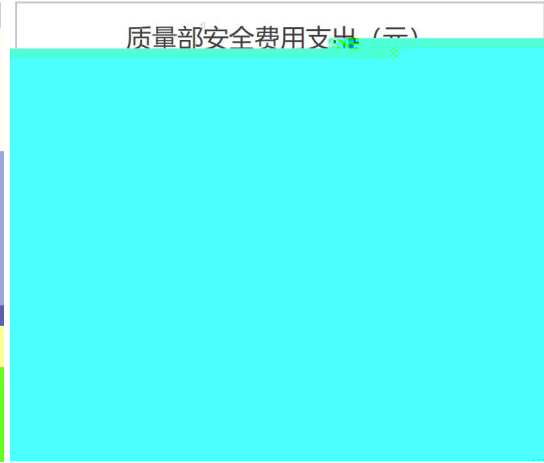
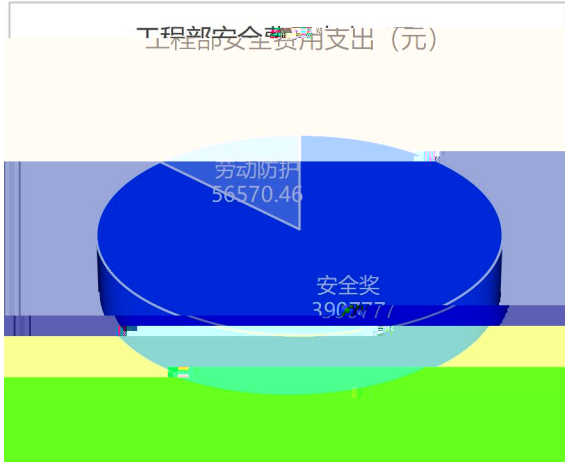

2022年度安全费用支出

| 费用类别 | 金额 (元) |
|------|-----------|
| 劳动防护 | 74258.16 |
| 安全奖 | 780755.6 |
| 培训教育 | 6162.40 |
| 标志标识 | 1278 |
| 隐患整改 | 4678 |
| 合计 | 851027.96 |



| 七 | | * |
|---|--|---|
| | | |
| | | |
| | | |
| | | |
| | | |

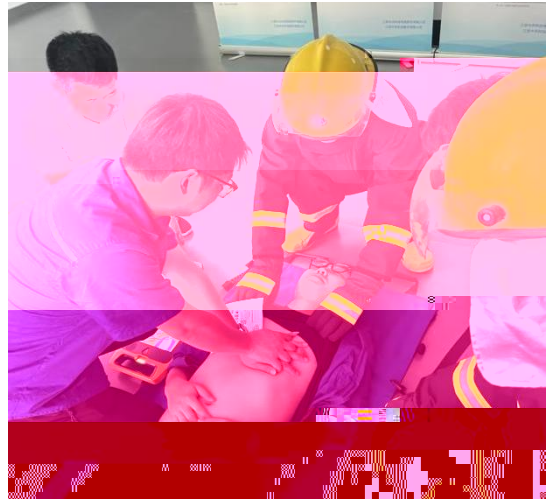

D





U





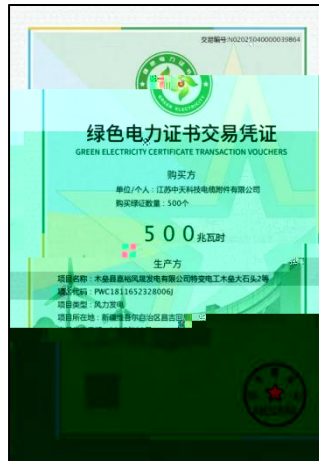

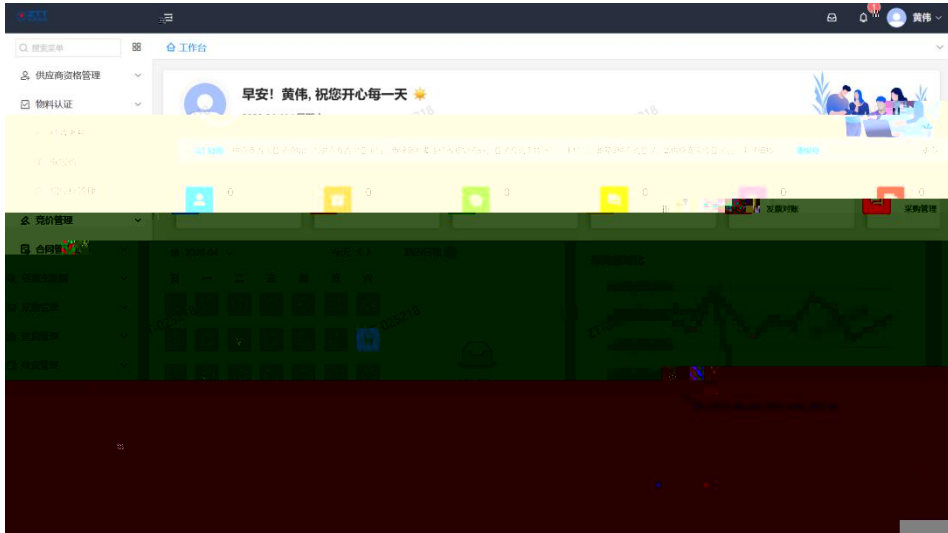





C

5 1/2TM

S
D



Ç 1/2 9 9 9 9 0

(0

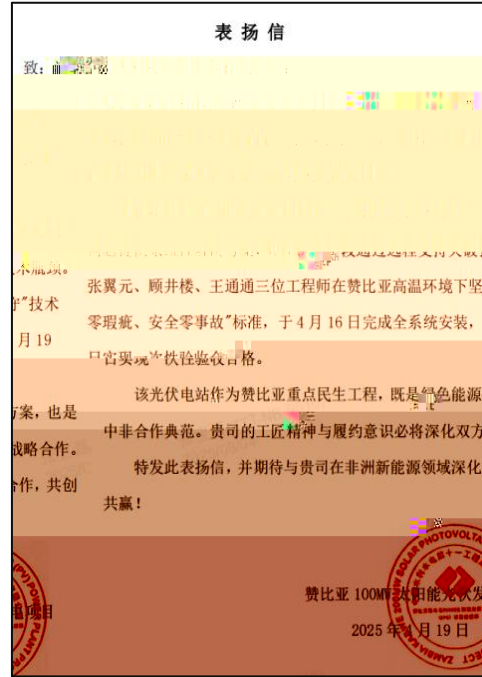
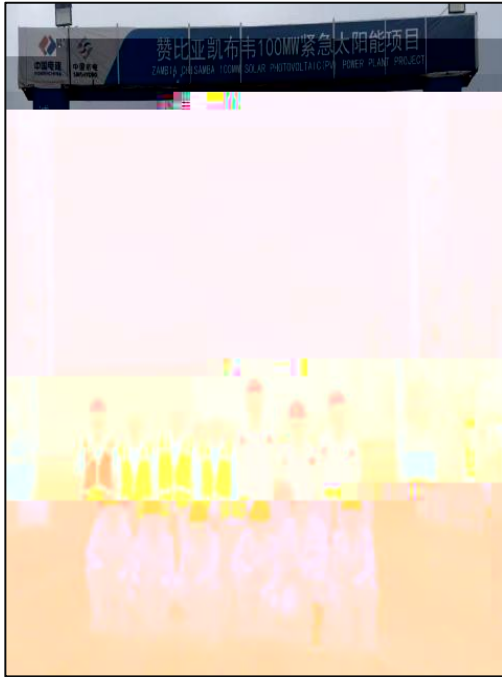





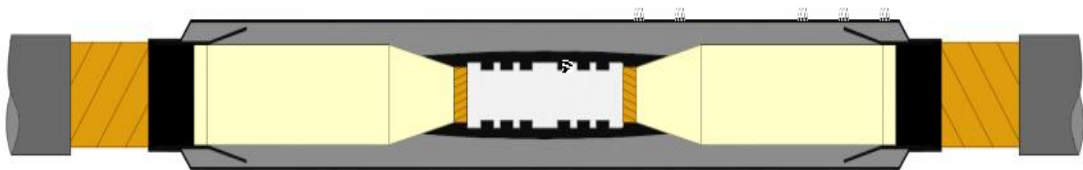
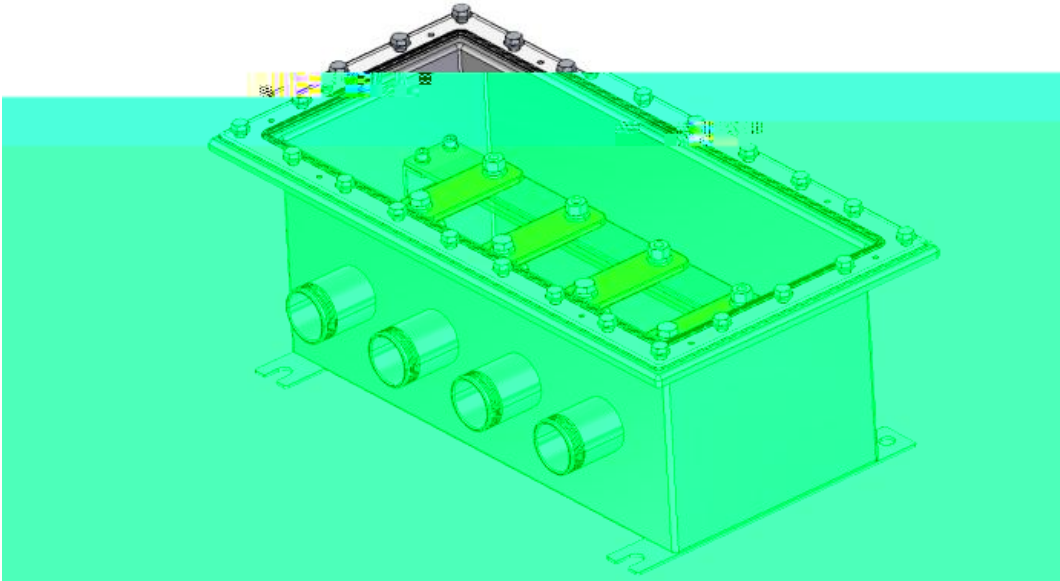



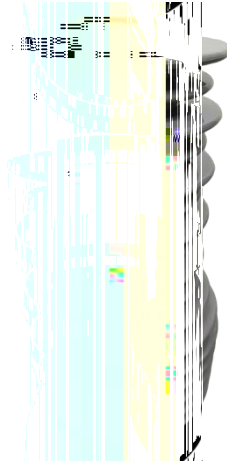
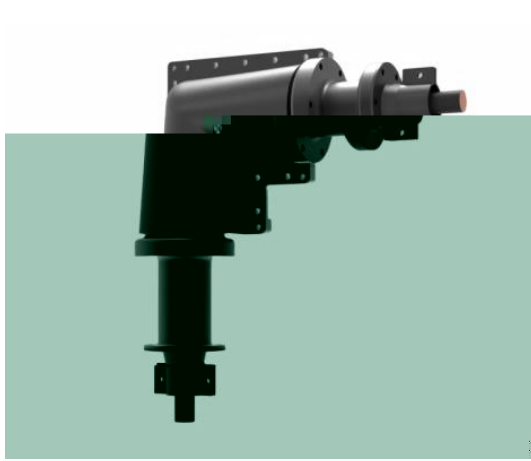



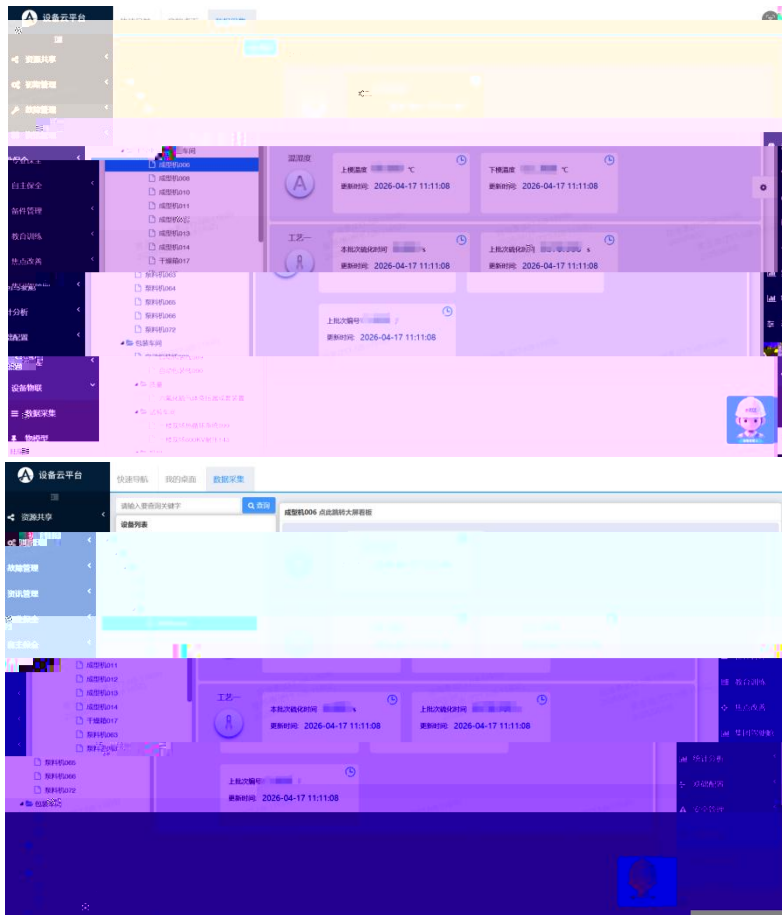

\hat{f}

L #, 2



∅

